

J. J. NOLAN.
Beading Attachment to Cutter-Heads.
No. 204,597. Patented June 4, 1878.

Fig. 1.

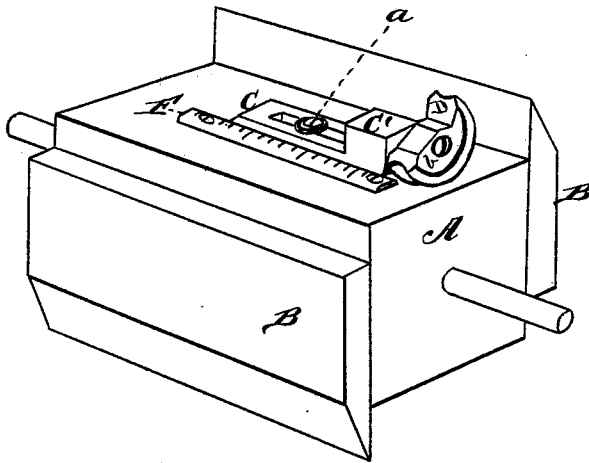
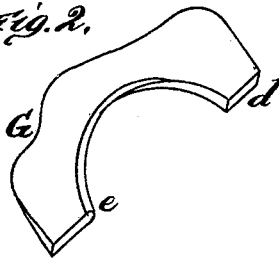

Fig. 2.



WITNESSES
Eng. H. Johnson,
James J. Sheehy

INVENTOR,
John J. Nolan.
J. Gilmore Smith & Co.
ATTORNEYS.

UNITED STATES PATENT OFFICE.

JOHN J. NOLAN, OF EAST SAGINAW, MICHIGAN.

IMPROVEMENT IN BEADING ATTACHMENTS TO CUTTER-HEADS.

Specification forming part of Letters Patent No. **204,597**, dated June 4, 1878; application filed March 9, 1878.

To all whom it may concern:

Be it known that I, JOHN J. NOLAN, of East Saginaw, in the county of Saginaw and State of Michigan, have invented a new and valuable Improvement in Beading-Tools; and I do hereby declare that the following is a full, clear, and exact description of the construction and operation of the same, reference being had to the annexed drawing, making a part of this specification, and to the letters and figures of reference marked thereon.

Figure 1 of the drawing is a perspective view of my beader-machine, and Fig. 2 is a perspective detail thereof.

My invention relates to planing-machines for dressing lumber; and it consists in the construction of a beader with stock and gage as an attachment for the planing-machine cylinder, as will be hereinafter more fully set forth.

The annexed drawing, to which reference is made, fully illustrates my invention.

A represents the cylinder of a planing-machine, provided with the planing-knives B B, said parts being constructed in any of the known and usual ways.

To the side of the cylinder A is, by means of a screw, *a*, secured a slotted plate, C, formed at one end with a head, C', and forming the stock of the beader. To the side of the head C' is, by means of a screw or bolt, *b*, secured the beader or beading-knife D. This beading-knife is made on a half-circle, as shown. By loosening the bolt *b* the beading-knife can be turned so as to bring the flat part up, and lumber may then be dressed without beading, without removing the beading-knife, and without said knife being in the way.

When it is desired to set the beader to work, the bolt *b* is again loosened, the beader turned with the knife ahead, and the bolt fastened again.

The plate C being slotted allows of the beader being moved backward and forward; and at the side of this plate a gage, F, is fastened to the cylinder, by which the beader may be set, in moving it back and forth, according to different widths of boards.

The beader or beading-knife D is made of a solid piece of steel and turned up on a lathe. In sharpening the same the filing is all done from the under side of the knife; hence there is no danger of getting the bead out of shape. This beader-knife can be attached to the cylinder of any planer.

To set the beader to work, I use a gage, G, by placing the beveled end *d* of said gage on the cylinder, and the other end, *e*, resting directly over the beader-knife; then turn the beader-knife until it raises the gage G one-sixteenth of an inch from the planer-knife.

What I claim as new, and desire to secure by Letters Patent, is—

1. The beader D, made on a half-circle, and adjustably attached to a stock fastened to a planer-cylinder, whereby the beader-knife may be turned out of the way when not desired for use, as herein set forth.

2. The combination, with a planer-cylinder, of the slotted adjustable plate C, with head C', and the adjustable beader D, made on a half-circle, substantially as and for the purposes herein set forth.

3. The gage F, secured to a planer-cylinder, A, in combination with the adjustable beader-stock and beader, for the purposes herein set forth.

In testimony that I claim the above I have hereunto subscribed my name in the presence of two witnesses.

JOHN J. NOLAN.

Witnesses:

JOSEPH PHILLIPS,
MICHAEL MADDEN.